

Liteway, Inc.

166 Haverford Road
Hicksville, NY 11801

516-931-2800

Interfacing the Current Loop Function of the INST/INSR-2001

This application note shows several ways that the INST/INSR-2001 current loop function may be interfaced with various sensors and power supplies.

INST-2001 Transmitter

The current-loop input to the INST-2001 is a 50 ohm resistor. As a result loop power must be provided from an external source. Figure 1 shows the use of the INST-2001 with a passive sensor and a separate current loop-power supply. Figure 2 shows the use of the INST-2001 and a self-powered sensor (with a built-in loop-power supply) while figure 3 shows the use of the INST-2001 with a common power supply for both a passive sensor and the INST-2001 itself. Note that the power supply used to power the loop must always be a DC supply for proper operation.

INSR-2001 Receiver

The current-loop output from the INSR-2001 is a variable impedance that determines the amount of current that can flow through it based on signals from the INST-2001. Figure 4 shows the use of the INSR-2001 with a passive current indicator and a separate current-loop power supply. Figure 5 shows the use of the INSR-2001 with a common power supply for both a passive current indicator and the INST-2001 itself. Note that the power supply used to power the loop must always be a DC supply for proper operation.

General

When connecting any type of power supply to either the INST-2001 or the INSR-2001 it is important to remember that position 3 on the signal terminal block and position 3 on the power terminal block are connected together as well as to the housing of both units.

Please refer to the INST/INSR-2001 Instruction Manual for additional details and specifications.

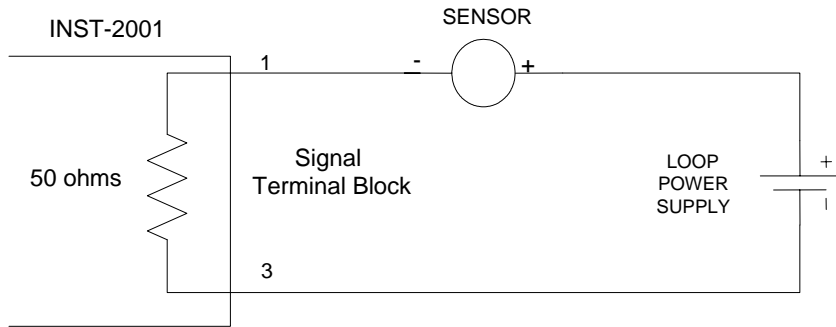

Figure 1, Using a Separate Loop Power Supply

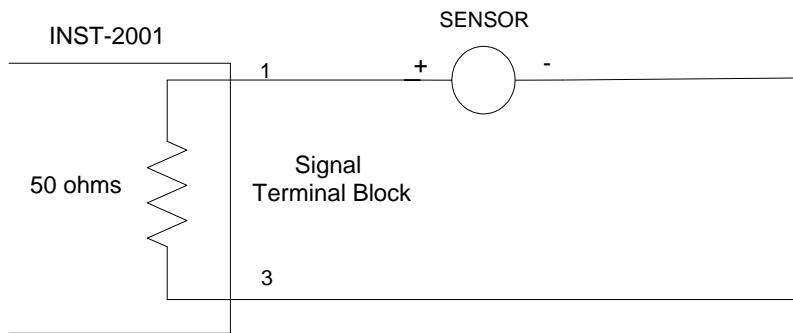

Figure 2, Using a Self Powered Sensor

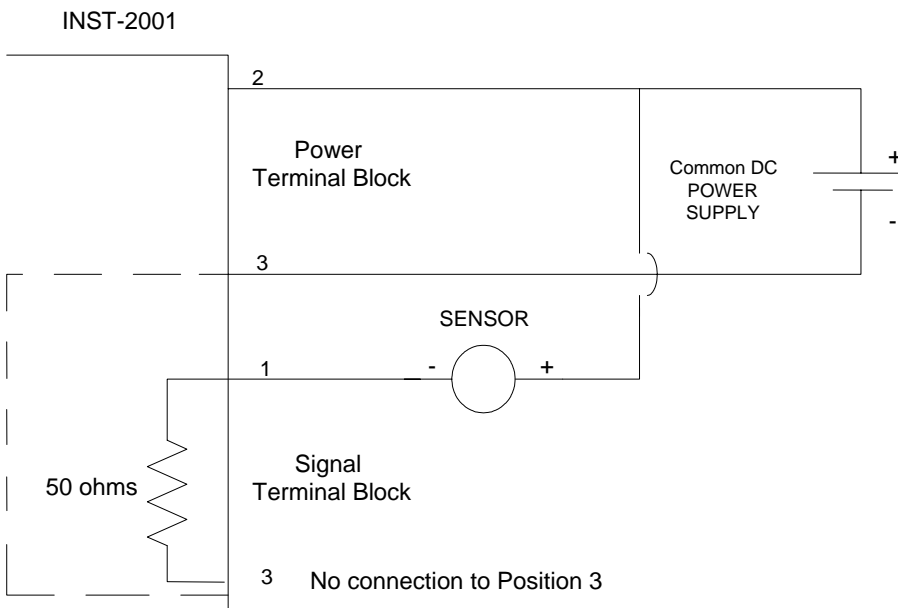

Figure 3, Using the Same Power Supply for the Sensor and the INST-2001

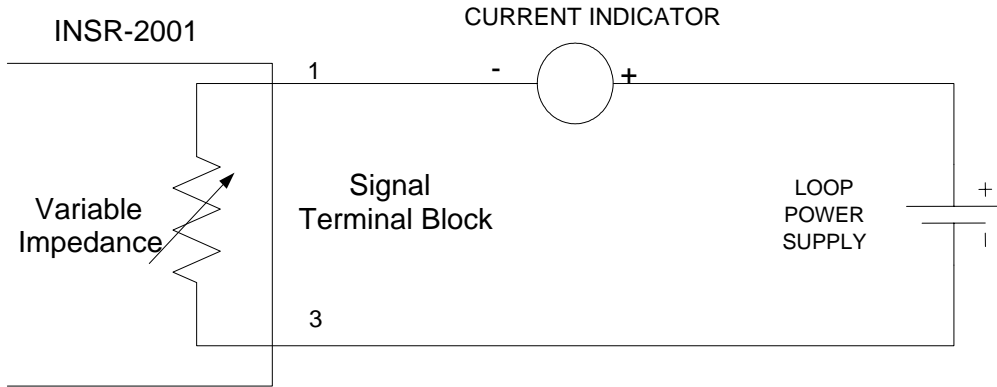

Figure 4, Using a Separate Loop Power Supply

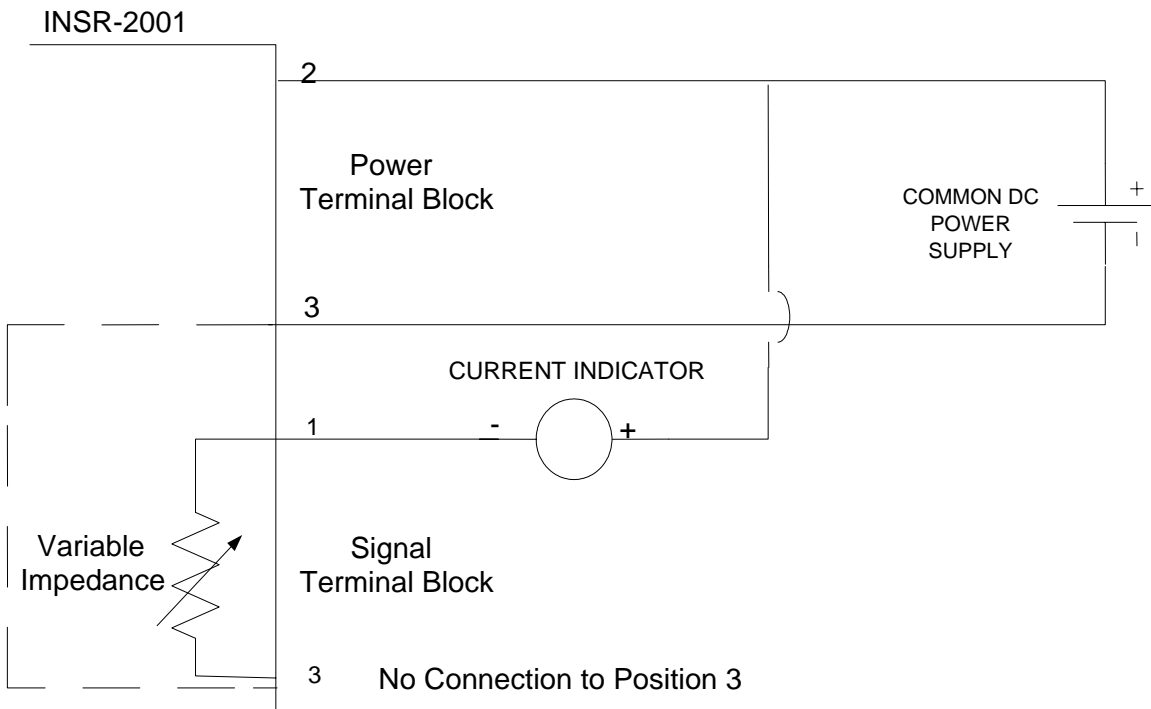

Figure 5, Using the same Power Supply for the Sensor and the INSR-2001