

RS-232 DATA TRANSMISSION SYSTEM

DX-7101

For Point-to-Point or Drop-and-Repeat Applications

The **Litelink™ DX-7101** is a data transceiver designed to transmit and receive RS-232 signals in a wide range of diverse applications. The unit is designed to operate in simplex, full duplex or drop-and-repeat modes and can easily be user configured for DTE or DCE operation. The DX-7101 will operate continuously at all data rates from DC to 200 Kb/sec.

Both multi-mode and single-mode versions are available and installation is totally adjustment free. In addition, integral indicators are provided to continuously indicate the presence of data signals as well as the presence of operating power making system troubleshooting simple.



Technical Specifications

Data Transmission Rate	DC to 200Kb/s
Operating Modes	Simplex, Duplex, Drop-and-Repeat
Configuration	DTE or DCE
Protocols Supported	RS-232
Operating Wavelength	850, 1310 or 1550nm
Optical Output Power (typ.)	-14 dBm (multi-mode) -10 dBm (single-mode)
Optical Loss Budget	0-15 dB (multi-mode) 0-18 dB (single-mode)
Optical Connectors	ST (multimode) FCPC (single-mode)
Signal Connector	Industry standard DB-25F
Operating Temperature	-35° to +75°C
Power Requirements*	11-24 VAC/DC @150mA
Physical Size (mm)	5.0" (127) x 3.0" (76) x 1.0" (25.4)

Note that all specifications are subject to change without prior notice.

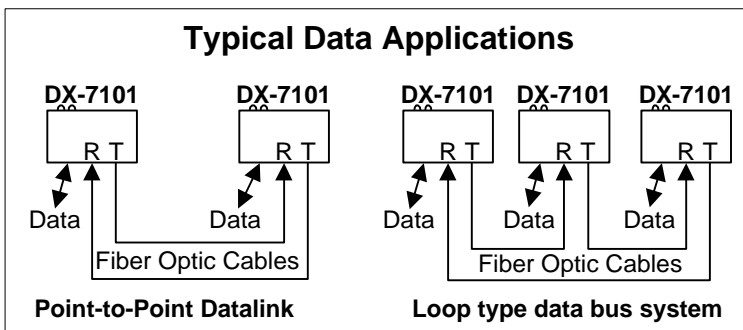

Important Features

- **DC to 200 Kb/s Data Rate**
- **Fully Adjustment Free**
- **DB-25F Signal Connector**
- **Signal and Power Indicators**
- **Stand-alone or Rack Mountable (same unit)**

Ordering Information

Transceiver, DX-7101-X

"X" = Wavelength/Fiber

- 1 = 850nm Multi-mode
- 3 = 1310nm Multi-mode
- 7 = 1310nm Single-mode
- 9 = 1550nm Single-mode

*For stand-alone operation order a PS-1205 power supply for each unit. For rack mounted operation all operating power is provided by the power supply used with the rack panel.