

Optical A/B Switch

OS-3121

For Optic Signal Selection Applications

The OS-3121 is a fiber optic switch that can be controlled remotely or through a front panel switch. The optical path through the units is purely optical; That is, there is no optical to electrical to optical conversion. There is no electrical loss or electrical bandwidth limit on the fiber optic path. The optical path can be select via a front panel switch or via contact closure input. In event of loss of power, the unit has a fail safe mode that opens the switch.

Common applications for this device are optical routing, system bypass, network cut off switch, and fiber optic testing. The OS-3121 control can be daisy chained to switch multiple optical connections. For two OS-3121 mounted in a single housing, order the OS-3221.



Technical Specifications

Switching Time	< 10 ms
Back Reflection	< -50 dB
Insertion Loss	< 1.3 dB
Cross Talk	< -50 dB
Switch Life cycle	> 1 Million cycles
Operating Wavelength	850/1310 or 1310/1550nm
Optical Connectors	ST, SC, or FCPC
Operating Temperature	0° to +70°C
Power Requirements*	11-24 VAC/DC @150 mA
Size (mm) Single	5.0" (127) x 3.0" (76) x 1.0" (25.4)
Size (mm) Dual	5.0" (127) x 3.0" (76) x 2.23" (56.6)

* -48VDC only models available by request.

Note that all specifications are subject to change without prior notice.

Important Features

- **Switching time < 10 ms**
- **Fail-safe return to bypass mode with loss of power.**
- **Small physical footprint**
- **Multimode or single-mode versions**
- **Power and Switch status indicators**

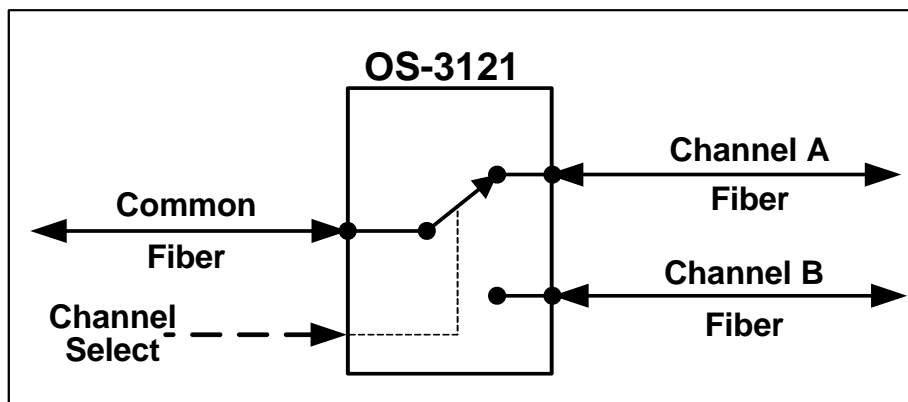

Ordering Information; OS-3121-# where "#" = Wavelength/Fiber/Connector

-3 = 850/1310nm Multi-mode ST/PC

-4 = 850/1310nm Multi-mode- SC/PC

-5 = 1310/1550nm Single-mode SC/PC

-7 = 1310/1550nm Single-mode FC/PC

LuxLink™
www.luxlink.com

166 Haverford Road
Hicksville, NY 11801
USA 516-931-2800