

Optical Node Bypass Switch

OS-3122/3222

For Fail-Safe Fiber Optic Bypass Applications

The OS-3122 is a "fiber optic relay" that can be electrically controlled. The optical path through the units is purely optical; i.e. there is no optical to electrical to optical conversion. There is no electrical loss or electrical bandwidth limit on the fiber optic path. The optical path can be select via a front panel switch or via contact closure input. In event of loss of power, the unit has a failsafe mode that returns the switch in to bypass mode. Common applications for this device are optical routing, system bypass, ring network restoration, and loop-back testing.

For applications where two independent optical channels need to be switched, such as dual SONET rings, the OS-3222 is two OS-3122 in a single package. For telco operations, -48 VDC versions are available. These versions are the OS-1202, OS-2202, respectively.

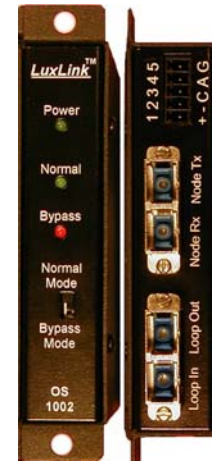

Technical Specifications

Switching Time	< 10 ms
Back Reflection	< -50 dB
Insertion Loss	< 1.1dB
Cross Talk	< -50 dB
Switch Life cycle	> 1 Million cycles
Operating Wavelength	850, 1310 or 1550nm
Optical Connectors	ST, SC, or FCPC
Operating Temperature	0° to +70°C
Power Requirements*	11-24 VAC/DC @150 mA
Size (mm) Single	5.0" (127) x 3.0" (76) x 1.0" (25.4)
Size (mm) Dual	5.0" (127) x 3.0" (76) x 2.23" (56.6)

*OS-1202, OS-2202 models are -48VDC only
Note that all specifications are subject to change without prior notice.

Important Features

- **Switching time < 10 ms**
- **Fail-safe return to bypass mode with loss of power.**
- **Small physical footprint**
- **Multimode or single-mode versions**
- **Power and Switch status indicators**

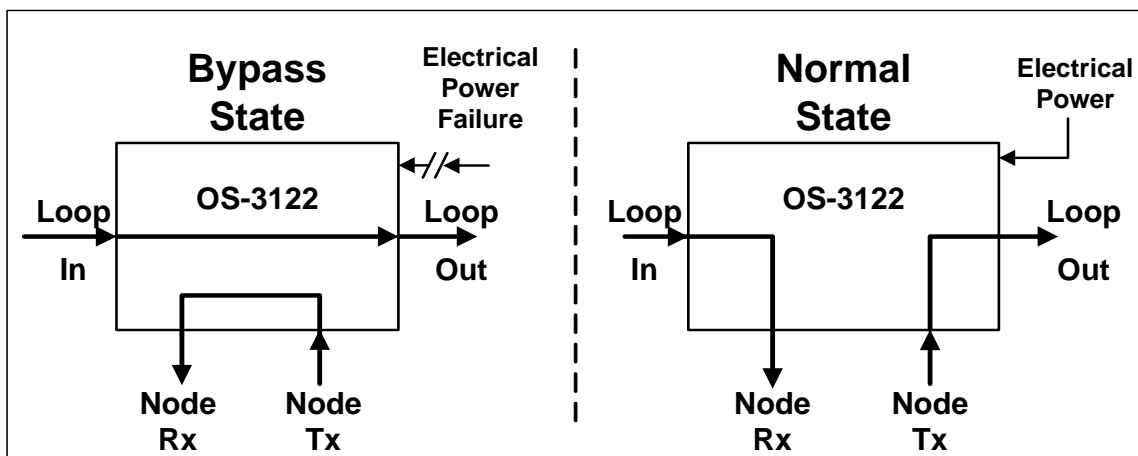

Ordering Information; OS-3122-# where "#" = Wavelength/Fiber/Connector

-3 = 850/1310nm Multi-mode ST/PC -4 = 850/1310nm Multi-mode- SC/PC
-5 = 1310/1550nm Single-mode SC/PC -7 = 1310/1550nm Single-mode FC/PC

LuxLink™
www.luxlink.com

166 Haverford Road
Hicksville, NY 11801
USA 516-931-2800