

WARRANTY

All fiber optic transmission systems, products and accessories manufactured by Liteway, Inc. and its subsidiaries are fully tested prior to shipment and are warranted against defective materials and workmanship for a period of two full years from the date of the original shipment. Should a problem occur, a Return Material Authorization Number (RMA) must be obtained from Liteway Inc. at (516) 931-2800 and the item returned to Liteway, Inc. 166 Haverford Road, Hicksville, NY 11801, USA, prepaid. Liteway Inc. will then, at its option repair or replace the defective item.

Liteway, Inc. maximum liability under this warranty is limited to the cost of the defective item only. No contingent liabilities of any kind are either assumed or implied.

Any items returned to Liteway, Inc. that have been misused, abused, damaged, modified, connected or adjusted in any way contrary to the instructions furnished by Liteway, Inc. or repaired by unauthorized personnel will not be covered by this warranty. Any non-warranty repairs required will be quoted at the current rate for such services.



Important Notices



CAUTION ! AVOID DIRECT EXPOSURE TO BEAM.

All -5, -7, -8, and -9 Models use laser diodes. These solid-state laser diodes are located in the optical ports of these units. Laser diodes produce invisible radiation that may be harmful to human eyes. Never look directly into the optical port of any fiber optic unit designed to operate with single-mode optical fiber.

NOT FOR LIFE SUPPORT SYSTEMS

Liteway, Inc. does not authorize or warrant any of its products or accessories for use in critical life support systems or applications of any kind.

OPERATING INSTRUCTIONS

Fiber Optic Universal

Data Transceiver

Model DX-7001



The DX-7001 may be used to transmit and receive EIA standard RS-232, RS-422, RS-485 (both 2-wire and 4-wire) and TTL signals at data rates from DC to 10 Mb/s. The unit may also be used for data conversion between any of the above protocols.

Technical Specifications

Data Rate	DC to 10 Mb/s
Protocols Supported	RS-232, RS-422, TTL, RS-485 (2 & 4 wire)
Operating Modes	Simplex, Duplex, Drop-and-Repeat
Rise / Fall times (typical)	100 nsec, (1.0 microsecond for RS-232)
Propagation delay RS-422	0.1 microseconds
Propagation delay RS-232	1.5 microseconds +/- 12 nanoseconds
Optical Output Power	-14 dBm (multimode), -10 dBm (single-mode)
Optical Loss Budget	0-15 dB (multimode), 0-18 dB (single-mode)
Signal Connectors	Removable terminal block
Power Requirements	11-24 VAC/DC @150ma
Temperature Range	-35° to +75°C
Physical Size	5.0" x 3.0 x 1.0" 127mm x 76mm x 25.4mm

All specifications are subject to change without prior notice.

Liteway[®]
www.Liteway.com

166 Haverford Road
Hicksville, NY 11801
USA 516-931-2800

Installation Instructions

The diagrams and tables below show the locations of the connectors and switches as well as the typical fiber and signal connections for the DX-7001 in both point-to-point and drop-and-repeat data transmission systems. For proper operation, the DX-7001 units should be connected and set accordingly. Be certain to check all connections, settings and voltages before applying power

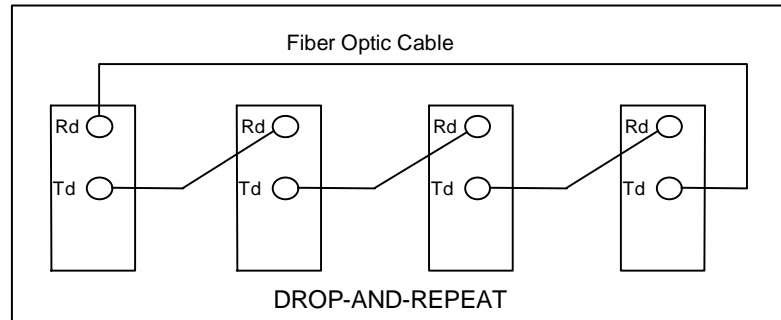
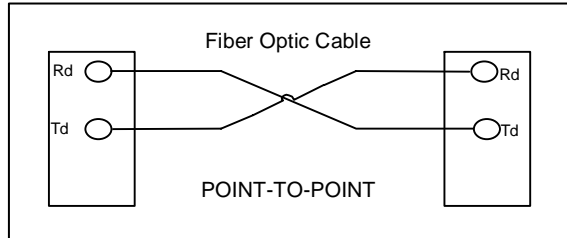

Note that in some Master/Slave installations, the DX-7001 specifically connected to the Master may have to be set to the Point-to-Point mode for proper operation.

Protocol Selection

Protocol is selected via the front panel 10 position DIP switch.

Protocol	1	2	3	4	5	6	7	8	9	10
RS-232	Off	On	Off	Off	Off	On	Off	*	Off	Off
RS-422	Off	On	Off	Off	On	On	Off	*	Off	Off
RS-485/2W	Off	On	On	On	On	Off	On	*	On	Off
RS-485/2W with RTS	Off	Off	On	On	On	Off	On	*	On	Off
RS-485/4W	Off	On	Off	Off	On	Off	Off	*	On	On
RS-485 4W , with RTS	Off	Off	Off	Off	On	Off	Off	*	On	On
TTL	On	On	Off	Off	On	On	Off	*	Off	On

DIP switch 9 connects an internal 120 ohm terminating resistors across data pins 1 & 2.
DIP switch 10 connects an internal 120 ohm terminating resistors across data pins 4 & 5.

*For point-to-point operation DIP switch 8 must be set to "Off". For drop-and-repeat operation, DIP switch 8 must be set to "On".
When using RS-485 2W the default transmit-to-receive switching(T/R) time is internally preset to 1.1ms (9600 b/s). This is adequate for most applications. If a different T/R time is required, please contact the factory for details on how to change the T/R time.

Alarm mode Selection (rear panel)

Sw1	Sw2	Alarm Function
0	0	Alarm disable
0	1	Td alarm only
1	0	Rd alarm only
1	1	Td or Rd alarm

Data Terminal Block Connections

Pin	Mode	Function
1	RS-232 & RS-422 & RS-485 & TTL	+data to be tx on the fiber
2	RS-422 & RS-485	-data to be tx on fiber
3	RS-232 & TTL & RTS In	Ground, Shield or RTS In
4*	RS-232 & RS-422 & RS-485 & TTL	+data rx from fiber
5*	RS-422 & RS-485	-data rx from fiber

* When in RS-485/2wire mode, Pin 1 is internally connected to pin 4, and pin 2 is internally connected to pin 5.

Power Terminal Block Connections

Pin	Function
1	Alarm output for use with optional Alarm Sensing Unit ALM-1000.
2	+11 to 24 DC or AC Volts input
3	AC or DC return (Common to Housing)

Indicator Lights

Indicator	Lights when
Pwr	Proper power is present.
Alrm	The loss of data alarm is activated and there is no data present.
Td	A data signal is being transmitted into the optical fiber.
Rd	A data signal is being received from the optical fiber.

Liteway[®]
www.Liteway.com

166 Haverford Road
Hicksville, NY 11801
USA 516-931-2800