

## WARRANTY

All fiber optic transmission systems, products and accessories manufactured by Liteway, Inc. and its subsidiaries are fully tested prior to shipment and are warranted against defective materials and workmanship for a period of three full years from the date of the original shipment. Should a problem occur, a Return Material Authorization Number (RMA) must be obtained from Liteway Inc. at (516) 931-2800 and the item returned to Liteway, Inc. 166 Haverford Road, Hicksville, NY 11801, USA, prepaid. Liteway Inc. will then, at its option repair or replace the defective item.

Liteway, Inc. maximum liability under this warranty is limited to the cost of the defective item only. No contingent liabilities of any kind are either assumed or implied.

Any items returned to Liteway, Inc. that have been misused, abused, damaged, modified, connected or adjusted in any way contrary to the instructions furnished by Liteway, Inc. or repaired by unauthorized personnel will not be covered by this warranty. Any non-warranty repairs required will be quoted at the current rate for such services.



### Important Notices



#### **CAUTION ! AVOID DIRECT EXPOSURE TO BEAM.**

All -5, -7, -8, and -9 Models use laser diodes. These solid-state laser diodes are located in the optical ports of these units. Laser diodes produce invisible radiation that may be harmful to human eyes. Never look directly into the optical port of any fiber optic unit designed to operate with single-mode optical fiber.

#### **NOT FOR LIFE SUPPORT SYSTEMS**

Liteway, Inc. does not authorize or warrant any of its products or accessories for use in critical life support systems or applications of any kind.

## OPERATING INSTRUCTIONS

### Optical Protection Switch

#### Single Channel Models OS-4121



The OS-4121 is an optical path protection switch, providing a self healing network.

#### Technical Specifications

Switching Time	< 10 ms
Back Reflection	< -50 dB
Insertion Loss	< 1.5 dB
Cross-talk	< -50 dB
Mechanical Life	> 1 Million cycles
Switch sensitivity	-28 dBm
Sensitivity Data rate	DC to 3Gb/s
Electrical Connector	5 pin removable terminal block
Temperature Range	-35° to +70°C
Operating Power Requirements	11-24 VAC/DC @ 150 mA -48 VDC (+/-2) for OS-1202, OS-2202
Physical Size (mm) single	5.0"(127)L x 1.0" (25.4)W x 3.0"(7)D

Models, wavelength, connector

-3 = 850/1310nm Multi-mode ST/PC	-4 = 850/1310nm Multi-mode- SC/PC
-5 = 1310/1550nm Single-mode SC/PC	-7 = 1310/1550nm Single-mode FC/PC

Specifications are subject to change without prior notice.



166 Haverford Road  
Hicksville, NY 11801  
USA 516-931-2800

# Installation Instructions

The OS-4121 optic switch detects loss of optical power in the primary optical path and automatically switches to the secondary (backup) path. When the primary link is restored, the network path is restored to the primary path. The optical protection switch can be controlled via three methods; front panel manual switch, remote control signal, or the automatic internal monitoring circuitry.

The optical path through the units is purely optical; i.e. there is no optical to electrical to optical conversion. So there is no electrical loss or electrical bandwidth limit on the fiber optic path.

Common applications for this device are optical routing, system bypass, ring network restoration, and loop-back testing.

The diagram below shows the typical application of the OS-4121. When in the Normal state, channel A is connected to the common port.

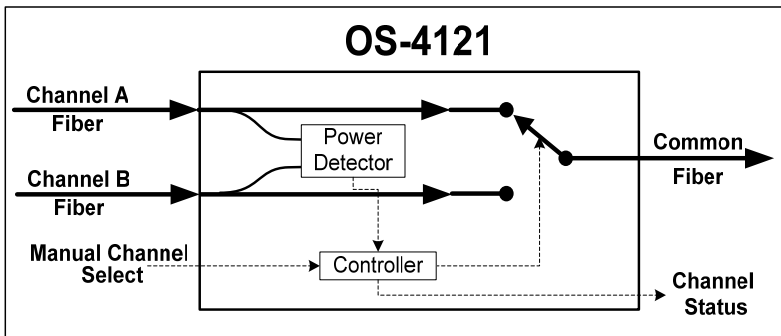

The OS-4121 switch will go in a bypass state under any of the following conditions:

- 1) There is a loss of electrical power
- 2) The front panel mode switch is put into Bypass mode
- 3) The rear panel control signal is grounded

When in the bypass state channel B is connected to the common port.

## Power Signal Terminal Block Connections

Pin	Label	Function
1	Ctl	Control Signal ( Connect to ground to place switch in bypass state ) when in auto mode.
2	Alm	Alarm* = Ground when primary or sec. signal is lost = Open otherwise
3	Gnd	Ground
4	+12V	Power input +12 VDC
4	VDC Rtn	Power Input Return
6	-48V	Power input -48 VDC

\* The Alarm signal can be used with the ALM-1000 unit to provide an audible alarm and dry contacts for remote station monitoring.

## Indicator Lights

Indicator	Lights when
Power	Proper power is present
Alarm	Alarm state, primary or secondary power level low.
Signal Primary	Signal on primary channel is > level selected
Signal Secondary	Signal on secondary channel > level selected.
Output Primary	Output is connected to Primary > level selected.
Output Secondary	Output is connected to Secondary > level selected

## Front Panel Auto / Primary / Secondary Mode Selector

When in auto mode, the optical switch can be controlled by the rear control signal or presence of power.

## Optical Power (+/- 1.0 dBm) Level Switch Setting

Switch	Level	Switch	Level	Switch	Level	Switch	Level
0	test	4	-35.0	8	-32.2	12	-31.0
1	-43.0	5	-34.0	9	-32.0	13	-30.3
2	-39.0	6	-33.0	10	-31.5	14	-30.0
3	-36.0	7	-32.5	11	-31.3	15	-29.8

Signal indicator will flash when signal power level is 0.5 dB < selected level. Note for 850nm, table sensitivity levels are 3dB lower