

WARRANTY

All fiber optic transmission systems, products and accessories manufactured by Liteway, Inc. and its subsidiaries are fully tested prior to shipment and are warranted against defective materials and workmanship for a period of two full years from the date of the original shipment. Should a problem occur, a Return Material Authorization Number (RMA) must be obtained from Liteway Inc. at (516) 931-2800 and the item returned to Liteway, Inc. 166 Haverford Road, Hicksville, NY 11801, USA, prepaid. Liteway Inc. will then, at its option repair or replace the defective item.

Liteway, Inc. maximum liability under this warranty is limited to the cost of the defective item only. No contingent liabilities of any kind are either assumed or implied.

Any items returned to Liteway, Inc. that have been misused, abused, damaged, modified, connected or adjusted in any way contrary to the instructions furnished by Liteway, Inc. or repaired by unauthorized personnel will not be covered by this warranty. Any non-warranty repairs required will be quoted at the current rate for such services.



Important Notices



CAUTION! AVOID DIRECT EXPOSURE TO BEAM.

All -5, -7, -8, and -9 Models use laser diodes. These solid-state laser diodes are located in the optical ports of these units. Laser diodes produce invisible radiation that may be harmful to human eyes. Never look directly into the optical port of any fiber optic unit designed to operate with single-mode optical fiber.

NOT FOR LIFE SUPPORT SYSTEMS

Liteway, Inc. does not authorize or warrant any of its products or accessories for use in critical life support systems or applications of any kind.

OPERATING INSTRUCTIONS

Redundant IRIG

Signal Switch

Model RSW-2002

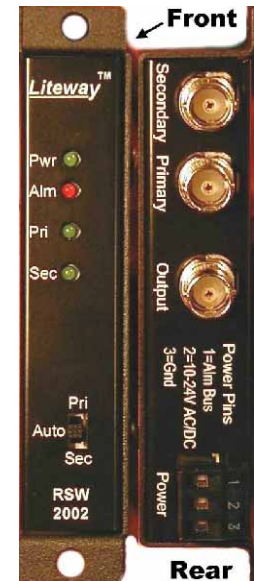

The RSW-2002 is a two input single output automatic switch designed to implement a redundant, fail-safe IRIG signal transmission

Technical Specifications

Bandwidth	100 Hz to 100 MHz
In / Out Impedance	600 ohms
In / Out Signal Level	3 volt peak to peak
Signal / Noise Ratio	75 dB minimum
Differential Gain	0.5% maximum
Phase Shift	0.3° maximum
Switch Over time	10 milliseconds maximum
Compatibility	IRIG A-H
Indicator Lights	Power, Input 1, Input 2, Fault, Alarm
Signal Connectors	BNC
Temperature Range	-35° to +75°C
Power Requirements	11-24 VAC/DC @150 mA
Physical Size (mm)	5.0"(127)L x 1.0" (25.4)W x 3.0"(76)D

All specifications are subject to change without prior notice.



Installation Instructions

The diagram below shows the typical installation of the RSW-2002 with IRGR-1001 and VR-1001 fiber optic video transmission units.

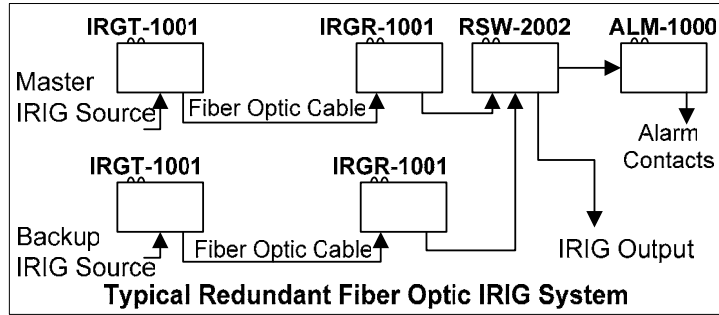

Upon loss of the primary IRIG signal, the RSW-2002 will automatically switch the remaining secondary (backup) IRIG signal to the output as well as activate the front panel alarm indicator and ALM-1000 Alarm Sensing Unit if used.

Power Terminal Block Connections

Pin	Function
1	Alarm output for use with optional Alarm Sensing Unit ALM-1000. No other connections should be made to this terminal
2	+11 to 24 DC or AC Volts input
3	AC or DC return (Common to Housing)

Be certain to check all connections, settings and voltages before applying power

Mode Switch

Setting	Function
Pri	Forces Primary feed to common output
Auto	Auto mode; If there is no signal on primary feed, but a signal on the secondary feed, the secondary feed is connected to common output. Otherwise, Primary feed connects to common output.
Sec	Forces Secondary feed to common output

Indicator Lights

Indicator	Lights when
Pwr	Proper power is present.
Alrm*	One or both video input signals are not present
Pri	A signal is present at Primary input
Sec	A signal is present at Secondary input.
Fault	The loss of the signal at Input 1 (Primary) has occurred and the video signal at Input 2 (Backup) has been routed to the output.

* Note that if the Alarm indicator is enabled the output for the optional ALM-1000 Alarm Sensing Unit will also be enabled.