

WARRANTY

All fiber optic transmission systems, products and accessories manufactured by Liteway, Inc. and its subsidiaries are fully tested prior to shipment and are warranted against defective materials and workmanship for a period of two full years from the date of the original shipment. Should a problem occur, a Return Material Authorization Number (RMA) must be obtained from Liteway Inc. at (516) 931-2800 and the item returned to Liteway, Inc. 166 Haverford Road, Hicksville, NY 11801, USA, prepaid. Liteway Inc. will then, at its option repair or replace the defective item.

Liteway, Inc. maximum liability under this warranty is limited to the cost of the defective item only. No contingent liabilities of any kind are either assumed or implied.

Any items returned to Liteway, Inc. that have been misused, abused, damaged, modified, connected or adjusted in any way contrary to the instructions furnished by Liteway, Inc. or repaired by unauthorized personnel will not be covered by this warranty. Any non-warranty repairs required will be quoted at the current rate for such services.



Important Notices



CAUTION ! AVOID DIRECT EXPOSURE TO BEAM.

All -5, -7, -8, and -9 Models use laser diodes. These solid-state laser diodes are located in the optical ports of these units. Laser diodes produce invisible radiation that may be harmful to human eyes. Never look directly into the optical port of any fiber optic unit designed to operate with single-mode optical fiber.

NOT FOR LIFE SUPPORT SYSTEMS

Liteway, Inc. does not authorize or warrant any of its products or accessories for use in critical life support systems or applications of any kind.

OPERATING INSTRUCTIONS

Redundant Video

Switch

Model RSW-3002



The RSW-1002 is a two input single output automatic switch designed to implement a redundant, fail-safe base-band video transmission system in full accordance with NTSC, PAL and SECAM specifications.

Technical Specifications

RF Switch Bandwidth	DC to 1 GHz
In/Out Impedance	50 ohms
Isolation	xx dB minimum
Insertion Loss	xx dB maximum
Signal Connectors	BNC (optional F-connector)
RF Rx Bandwidth	5 to 750 M Hz (indicator only)
Rx In Signal Level	dBmV peak to peak
Rx Hysteresis	2-3 dB
Indicator Lights	Pwr, Primary, Secondary, Alarm
Power & control connectors	Removable terminal Block
Temperature Range	-35° to +75°C
Power Requirements	11-24 VAC/DC @ 150 mA
Physical Size (mm)	5.0"(127)L x 1.0" (25.4)W x 3.0"(7)D

All specifications are subject to change without prior notice.

Litelink[™]
Fiber Optic Transmission Systems

Liteway,[™] Inc.
www.Liteway.com
USA 516-931-2800

Installation Instructions

The diagram below shows the typical installation of the RSW-3002.

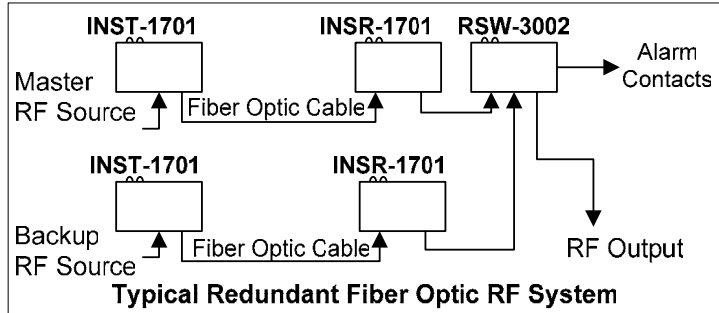

Upon loss of the primary signal, the RSW-3002 will
 Automatically switch the remaining secondary (backup) signal
 Activate the front panel Alarm (**Alm**) indicator.
 Sound the Alarm audio alert if enabled.
 Switch the external relay contacts.

Mode Switch

Setting	Function
Pri	Forces Primary feed to common output
Auto	Auto mode; If there is no signal on primary feed, but a signal on the secondary feed, the secondary feed is connected to common output. Otherwise, Primary feed connects to common output.
Sec	Forces Secondary feed to common output

Audio Alert Switch

When enabled, this allows an audible alert if a fault condition is present

Indicator Lights

Indicator	Lights when
Pwr	Proper power is present.
Alrm*	One or both input signals are not present
Pri	A signal is present at Primary input
Sec	A signal is present at Secondary input.
Fault	The loss of the video signal at Input 1 (Primary) has occurred and the video signal at Input 2 (Backup) has been routed to the output.

* Note that if the Alm indicator is enabled the output for the optional ALM-1000 Alarm Sensing Unit will also be enabled.

3 Pin Power Terminal Block Connections

Pin	Function
1	Alarm output for use with optional Alarm Sensing Unit ALM-1000. No other connections should be made to this terminal
2	+11 to 24 DC or AC Volts input
3	Ground, AC or DC return (Common to Housing)

Be certain to check all connections, settings and voltages before applying power

5 Pin Control Terminal Block Connector Block

Pin	Function
Relay contacts (2 Amp dry contact)	
1	Normally Open Contact
2	Common Contact
3	Normally Closed Contact
External control of Mode	
4	Ground to Force Primary output
5	Ground to Force Secondary output