

WARRANTY

All fiber optic transmission systems, products and accessories manufactured by Liteway, Inc. and its subsidiaries are fully tested prior to shipment and are warranted against defective materials and workmanship for a period of five full years from the date of the original shipment. Should a problem occur, a Return Material Authorization Number (RMA) must be obtained from Liteway Inc. at (516) 931-2800 and the item returned to Liteway, Inc. 166 Haverford Road, Hicksville, NY 11801, USA, prepaid. Liteway Inc. will then, at its option repair or replace the defective item.

Liteway, Inc. maximum liability under this warranty is limited to the cost of the defective item only. No contingent liabilities of any kind are either assumed or implied.

Any items returned to Liteway, Inc. that have been misused, abused, damaged, modified, connected or adjusted in any way contrary to the instructions furnished by Liteway, Inc. or repaired by unauthorized personnel will not be covered by this warranty. Any non-warranty repairs required will be quoted at the current rate for such services.



Important Notices



CAUTION ! AVOID DIRECT EXPOSURE TO BEAM.

All -7,-8, and -9 Models use laser diodes. These solid-state laser diodes are located in the optical ports of these units. Laser diodes produce invisible radiation that may be harmful to human eyes. Never look directly into the optical port of any fiber optic unit designed to operate with single-mode optical fiber.

NOT FOR LIFE SUPPORT SYSTEMS

Liteway, Inc. does not authorize or warrant any of its products or accessories for use in critical life support systems or applications of any kind.

OPERATING INSTRUCTIONS

LuxLink® Fiber Optic TTTL/RS-422 Transmission System

**DT-7201, DR-7201,
DX-7201**



The DT/DR-7201 system consists of the DT-7201 transmitter and DR-7201 receiver or two DX-7201 transceivers. This system will transmit standard medium speed TTL signals from DC to 50 Mb/s, or RS-422 signals DC-20Mb/s

Technical Specifications

Data Rate	DC-50 Mb/s (TTL) , DC-20Mb/s(RS-422)
Protocols supported	TTL (50 ohms/Hi-Z), RS-422
Rise / Fall Time	<12 nanoseconds
Propagation delay RS422	22.5ns (-1, -3), 14.5ns (-7, -9)
Propagation delay TTL	20.5ns (-1, -3), 12.5ns (-7, -9)
Signal voltage range	0-5V (TTL), 200mV -5V (422)
Signal Connectors	BNC, Removable Terminal Block
Operating Wavelength	850 (-1)nm, 1310 (-3,-7)nm, 1550 (-9)nm
Optical Output Power	-15 dBm typical (multimode, single-mode)
Optical Loss Budget	0 – 10 dB (multimode, single-mode)
Fibers Accommodated	1 multimode (-1, -3), 1 single-mode (-7, -9)
Operating Temperature	-35° to +75°C
Power Requirements	11-24 VAC/DC @ 150 mA
Physical Size (mm)	5.0"(127)L x 3.0"(76)D x 1.0"(25.4)W

All specifications measured with 1Km of 62.5u multimode fiber.

All specifications are subject to change without prior notice.

Installation Instructions

The diagrams below show the location of the connectors and mode configuration switches for the DT-7201 and the DR-7201. For proper operation, the units should always be connected as shown.

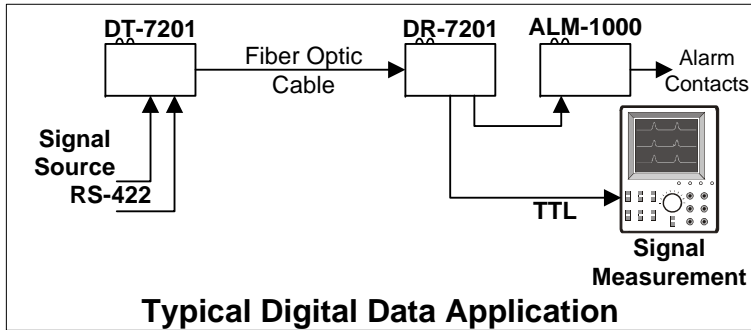

Configuration DIP Switch Settings

Before applying power set the 10 position DIP switch for the mode of operation desired as follows:

Protocol	1	2	3	4	5	6	7	8	9	10
TTL 50ohm	Off	Off	Off	Off	On	On	Off	Off	On	*
TTL Hi-Z	Off	Off	Off	Off	On	On	Off	Off	Off	*
RS-422	On	On	On	On	Off	Off	On	On	Off	*

*Switch 10 is used to select or defeat the Alarm mode.
 On = Alarm defeated enabled, (alarm mode not active)
 Off = Alarm defeated disable, (alarm mode active)
 Note that on the RX switch 9 has no effect.

Signal Input /Output Considerations

The TTL 50-ohm mode presents a 50-ohm load in the DT-7201 and requires that the DR-7201 be terminated in 50 or 75 ohms.

The Hi-Z TTL mode presents a 3K TTL load in the DT-7201 and requires that the DR-7201 be terminated in 3K TTL load.

The TTL Signals use both the BNC connectors and the terminal blocks to accommodate the signals.

The RS-422 mode is compatible with EIA standard RS-422 and uses the terminal blocks only for signals. There are no internal 120 ohm termination resistors. If required you must add them externally.

Signal Terminal Block Connections

Pin	Function
1	TTL, RS-422+ Output
2	RS-422 - Output
3	Ground or Shield
4	RS-422 - Input
5	TTL, RS-422 + Input

BNC Connections

BNC Center Pin TTL input or output
 BNC Shell TTL common and case ground.

Power Terminal Block Connections

Pin	Function
1	Alarm output for use with optional Alarm Sensing Unit ALM-1000. No other connections should be made to this terminal.
2	+11 to 24 DC or AC Volts input
3	AC or DC return (Common to Housing)

Be certain to check all connections, settings and voltages before applying power

Indicator Lights

Indicator	Lights when
Pwr	Proper power is present.
Alrm	The loss of data alarm is activated there is no data present.
Sig	A data signal is being transmitted or received. At low data rates these indicators may blink with data.

For the DX-7201

you must connect the transmit fiber of one unit to the receiver of the other unit

