

WARRANTY

All fiber optic transmission systems, products and accessories manufactured by Liteway, Inc. and its subsidiaries are fully tested prior to shipment and are warranted against defective materials and workmanship for a period of five full years from the date of the original shipment. Should a problem occur, a Return Material Authorization Number (RMA) must be obtained from Liteway Inc. at (516) 931-2800 and the item returned to Liteway, Inc. 166 Haverford Road, Hicksville, NY 11801, USA, prepaid. Liteway Inc. will then, at its option repair or replace the defective item.

Liteway, Inc. maximum liability under this warranty is limited to the cost of the defective item only. No contingent liabilities of any kind are either assumed or implied.

Any items returned to Liteway, Inc. that have been misused, abused, damaged, modified, connected or adjusted in any way contrary to the instructions furnished by Liteway, Inc. or repaired by unauthorized personnel will not be covered by this warranty. Any non-warranty repairs required will be quoted at the current rate for such services.



Important Notices



CAUTION! AVOID DIRECT EXPOSURE TO BEAM.

All -5, -7, -8, and -9 Models use laser diodes. These solid-state laser diodes are located in the optical ports of these units. Laser diodes produce invisible radiation that may be harmful to human eyes. Never look directly into the optical port of any fiber optic unit designed to operate with single-mode optical fiber.

NOT FOR LIFE SUPPORT SYSTEMS

Liteway, Inc. does not authorize or warrant any of its products or accessories for use in critical life support systems or applications of any kind.

Operating Instructions

LuxLink® Fiber Optic Digital Current Loop Transmission System

Model DX-7501



The **LuxLink®** DX-7501 is a data transceiver designed to transmit and receive digital current loop signals in a wide range of diverse applications. The unit is designed to operate in simplex or full duplex modes. The DX-7501 can easily be user configured for active or passive 20 or 30-mA current loop operation and will operate continuously at all data rates from DC to 100 Kb/sec.

Technical Specifications

Data Transmission Rate	DC to 100 Kb/s
Protocols Supported	Current Loop 20 mA or 30 mA
Protocol Modes	Active and Passive
Operating Modes	Simplex, Duplex
Rise/Fall Times (typ.)	1.0 microsecond
Operating Wavelength	850nm (-1), 1310nm (-3,-7), 1550nm (-9)
Optical Loss Budget	0-15 dB (multimode) 0-18 dB (single-mode)
Fibers Accommodated	1 multimode (-1,-3), 1 single-mode (-7,-9)
Operating Temperature	-35° to +75°C
Power Requirements	10-24 VAC/DC @150 mA
Physical Size (mm)	5.0"(127)L x 3.0"(76)D x 1.0" (25.4)W

All specifications measured with 1Km of 62.5u multimode fiber.

All specifications are subject to change without prior notice.

Installation Instructions

The diagram below shows the typical installation of the Digital current loop transceiver, DX-7501.

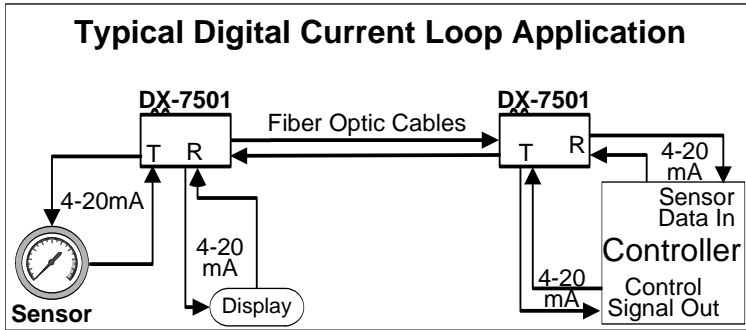

Current loops can be passive or active and the DX-7501 can function with both types. A passive loop is expecting the DX-7501, to provide the current source. An active loop is expecting the device connected to the DX-7501 to provide the current source. Active or passive loops are selected by using the appropriate terminal block connections.

Note that improper hookup can damage the equipment!!

Data Terminal Block Connections

There are two separate 5-pin removable terminal blocks for data connections.

- "Data Rx" is data received from the "Rd" optical fiber.
- "Data TX" is data to be transmitted onto the "Td" optical fiber.

Pin	Label	Description
1	+	Current Source (passive or active)
2		Wire (connect) to pin 3 for 30mA mode
3	-Pas	Current return for Passive loop, i.e. DX-7501 does not provide current source.
4	-Act	Current return for Active loop, i.e. DX-7501, provided current source.
5		Case Ground.

Note; Pins 1 though 4 are floating, (they are not connected to ground). In addition Data Rx and Data Tx are not isolated from each other.

Note that improper hookup can damage the equipment!!



Typical examples of use;

Scenario, Signal to be transmitted onto fiber.	Connections
A passive transmitter needing a 20mA current source	"Data to Tx" terminal block: Pins 1(+) and pin 4 (+Pas)
A passive transmitter needing a 30mA current source	"Data to Tx" terminal block: Pin 1(+) and pin 4(-Act). jump pins 2 & 3
An active transmitter which has its own current source, or a passive sensor with an external current source	"Data to Tx" terminal block: Pin 1(+) and pin 3(-Pas).
Scenario, Signal to be Received from fiber	Connections
A passive data receiver expecting to receive data, needing an external current source	"Data Rx" terminal block: Pin 1(+) and pin 4(-Act)
A active receiver expecting to receive data, with an internal current source	"Data Rx" terminal block: Pin 1(+) and pin 3(-Pas).

Power Terminal Block Connections

Pin	Function
1	Alarm output for use with optional Alarm Sensing Unit ALM-1000. No other connections should be made to this terminal
2	+11 to 24 DC or AC Volts input
3	AC or DC return (Common to Housing)

Be certain to check all connections, settings and voltages before applying power

Indicator Lights

Indicator	Lights when
Pwr	Proper power is present.
Alrm	The loss of signal alarm is activated and there is no signal present
Rx	A data signal is being received from fiber.
Tx	A data signal is being transmitted onto fiber.

Alarm Mode Selection

The front panel alarm switches enables or disables an alarm condition for transmit or received data. An alarm condition occurs when there is no data transition present for a period of time. This alarm feature is for use with the ALM-1001 alarm module.