

WARRANTY

All fiber optic transmission systems, products and accessories manufactured by Liteway, Inc. and its subsidiaries are fully tested prior to shipment and are warranted against defective materials and workmanship for a period of five full years from the date of the original shipment. Should a problem occur, a Return Material Authorization Number (RMA) must be obtained from Liteway Inc. at (516) 931-2800 and the item returned to Liteway, Inc. 166 Haverford Road, Hicksville, NY 11801, USA, prepaid. Liteway Inc. will then, at its option repair or replace the defective item.

Liteway, Inc. maximum liability under this warranty is limited to the cost of the defective item only. No contingent liabilities of any kind are either assumed or implied.

Any items returned to Liteway, Inc. that have been misused, abused, damaged, modified, connected or adjusted in any way contrary to the instructions furnished by Liteway, Inc. or repaired by unauthorized personnel will not be covered by this warranty. Any non-warranty repairs required will be quoted at the current rate for such services.



Important Notices



CAUTION ! AVOID DIRECT EXPOSURE TO BEAM.

All -5, -7, -8, and -9 Models use laser diodes. These solid-state laser diodes are located in the optical ports of these units. Laser diodes produce invisible radiation that may be harmful to human eyes. Never look directly into the optical port of any fiber optic unit designed to operate with single-mode optical fiber.

NOT FOR LIFE SUPPORT SYSTEMS

Liteway, Inc. does not authorize or warrant any of its products or accessories for use in critical life support systems or applications of any kind.

OPERATING INSTRUCTIONS

LuxLink® Fiber Optic High Speed CAN Bus Repeater

Model DX-7601



The **LuxLink®** DX-7601 is a CAN Bus repeater system designed to extend high speed CAN (Controller Area Network) signals. This CAN bus repeater supports the CAN-based higher level protocols, eg CAL*, CAN Kingdom*, CANOpen*, DeviceNet*, Smart Distributed Systems(SDS)*.

Technical Specifications

Data Rate	10 Kb/s to 1 Mb/s
Protocols Supported	CAN (ISO 11898-2)
System Delay	<2 microseconds
Isolation	> 3K Volts
Indicators	Pwr, Alm, Rx, Tx
Operating Wavelength	850nm,1310nm or 1550nm
Optical Loss Budget	0-10 dB (multimode or single-mode)
Signal Connectors	Removable terminal block
Power Requirements	11-24 VAC/DC @150 mA
Operating Temperature	-35° to +75° C
Physical Size (mm)	5.0"(127) x 3.0"(76) x 1.0"(25.4)

All specifications are subject to change without prior notice.

Note that Link distance can be limited by signaling rate as specified by the CAN specification due to bus arbitration.

* These are registered trademarks of other companies and are used only for explanation and to the owners benefit.

Installation Instructions

The below diagram show a typical application and tables below show the removable terminal block connections

For proper operation, the DX-7601 units should be connected accordingly. Be certain to check all connections and voltages before applying power

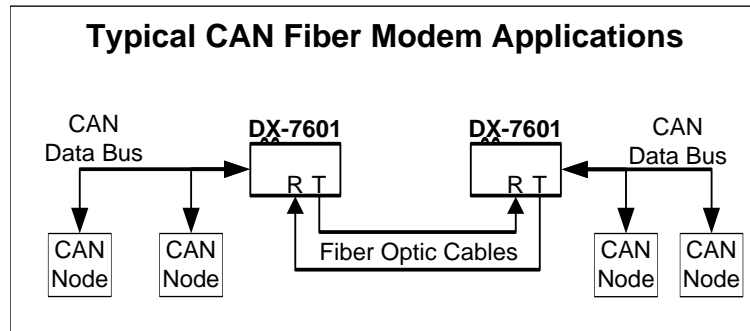

Protocol Selection

Note; A 120 ohm termination resistor is usually connected to the bus between CAN H and CAN L. This resistor is may be required on long electrical cable links for the system may not operate properly.

Data Terminal Block Connections

Pin	Function
1	Not used (reserved)
2	Not used (reserved)
3	Ground *
4	CAN High
5	CAN Low

* Pin 3 must be connected to system ground for the system to work.

Power Terminal Block Connections

Pin	Function
1	Alarm output for use with optional Alarm Sensing Unit ALM-1000.
2	+11 to 24 DC or AC
3	AC or DC return (Common to Housing)

106500 Rev M

Indicator Lights

Indicator	Lights when
Pwr	Proper power is present.
Alrm	The loss of data alarm is activated when there is no data present.
Td	A data signal is being transmitted into the optical fiber.
Rd	A data signal is being received from the optical fiber.

Practical Bus Length*

The full CAN specification contains both electrical and software protocols. If your system is strictly following the CAN software protocols, then the link distance is limited by signaling rate as specified by the CAN specification due to bus arbitration (physical effects of loop delays, delay of bus lines, differences in bit time length). This limit is in the below table. (See the ISO 11898 specification for further information.)

Bit Rate	Bus Length	Nominal Bit-Time
1 MBit/s	30 m	1 us
800 kbit/s	50 m	1.25 us
500 kbit/s	100 m	2 us
250 kbit/s	250 m	4 us
125 kbit/s	500 m	8 us
62.5 kbit/s	1000 m	120 us
20 kbit/s	2500 m	50 us
10 kbit/s	5000 m	100 us

Many customers are only using the CAN electrical protocols. If this is your case and system design is not limited by standard CAN bus arbitration, the DX-7601 can extend your link transmission distance as far as 2 to 40 miles depending on the optical model selected.

Maximum length of the electrical cable to and from the DX-7601 is still determined by physical effects, which is voltage drop due to series resistance of bus cable.