

## WARRANTY

All fiber optic transmission systems, products and accessories manufactured by Liteway, Inc. and its subsidiaries are fully tested prior to shipment and are warranted against defective materials and workmanship for a period of five full years from the date of the original shipment. Should a problem occur, a Return Material Authorization Number (RMA) must be obtained from Liteway Inc. at (516) 931-2800 and the item returned to Liteway, Inc. 166 Haverford Road, Hicksville, NY 11801, USA, prepaid. Liteway Inc. will then, at its option repair or replace the defective item.

Liteway, Inc. maximum liability under this warranty is limited to the cost of the defective item only. No contingent liabilities of any kind are either assumed or implied.

Any items returned to Liteway, Inc. that have been misused, abused, damaged, modified, connected or adjusted in any way contrary to the instructions furnished by Liteway, Inc. or repaired by unauthorized personnel will not be covered by this warranty. Any non-warranty repairs required will be quoted at the current rate for such services.



### Important Notices



#### **CAUTION ! AVOID DIRECT EXPOSURE TO BEAM.**

All -5, -7, -8, and -9 Models use laser diodes. These solid-state laser diodes are located in the optical ports of these units. Laser diodes produce invisible radiation that may be harmful to human eyes. Never look directly into the optical port of any fiber optic unit designed to operate with single-mode optical fiber.

#### **NOT FOR LIFE SUPPORT SYSTEMS**

Liteway, Inc. does not authorize or warrant any of its products or accessories for use in critical life support systems or applications of any kind.

## OPERATING INSTRUCTIONS

### **LuxLink®** **IRIG Format Converter** **Model IRGC-3003**

### **DCLS to/or from** **Modulated Format Conversion**

The **LuxLink®** IRGC-3003 is IRIG format converter that is used to converting modulated IRIG to/or from DCLS. There is one a buffered IRIG input with loop through output, and three individual converted electrical output signals.



### Technical Specifications

Formats	Modulated or DCLS
Protocols	IRIG-A, B, E, G
<b>Modulated;</b>	
Signal Bandwidth	100 Hz to 100 KHz (+0,-3dB)
Input / Output Impedance	600 ohms
Input / Output Level	1V rms (3 Vpp) typical
Signal/Noise Ratio	60 dB minimum
Linearity	2% typical
<b>DCLS;</b>	
Data Rate	DC to 1000 pps
Rise / Fall Time	20 nsec typical
Input / Output Impedance	50 ohms
Input / Output Level	TTL (3.5 volts)
Bit Error Rate	10E9 minimum
Propagation Delay	35 ns
Offset between outputs	< 5 ns
Signal Connector	BNC
Power Connector	3 pin removable terminal block
MTBF (MIL-HDBK-217)	>100,000 Hours
Temperature Range	-35° to +75°C
Power Requirements	11-24 VAC/DC @250 mA
Physical Size (mm)	5.0"(127)L x 3.0"(76)D x 1.0" (25.4)W

Specifications are subject to change without prior notice.

# Installation Instructions

IRIG A through E, NASA-36 and IEEE 1344 are supported and the mode of operation (type of conversion) and carrier resolution is selectable by means of the front panel dip switch.

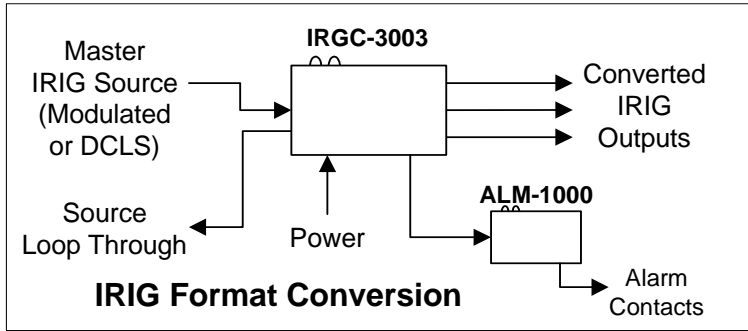

## Configuration DIP Switch Settings

Before applying power set the 10 position DIP switch for the mode of operation desired as follows:

Demodulator Mode (Modulated Analog in , Digital DCLS Out)

Protocol	1	2	3	4	5	6	7	8	9	10
1000pps(A)	On	Off	Off	Off	Off	Off	Off	Off	Off	On
100pps (B)	On	On	Off	Off	Off	Off	Off	Off	Off	On
10pps (E)	Off	On	On	Off	Off	Off	Off	Off	Off	On

Note; Upon turn on depending on the switch settings or nature of the input IRIG signal, the selected output may take up to 15 seconds to lock to the incoming signal.

Modulator Mode (Digital DCLS In, Modulated Analog out )

Protocol	1	2	3	4	5	6	7	8	9	10
100 KHz	Off	Off	Off	Off	On	On	Off	Off	On	Off
10 KHz	Off	Off	Off	On	Off	Off	On	Off	On	Off
1 KHz	Off	Off	Off	On	On	Off	Off	On	On	Off

## Power Terminal Block Connections

Pin	Function
1	Alarm output for use with optional Alarm Sensing Unit ALM-1000. No other connections should be made to this terminal.
2	+11 to 24 DC or AC Volts input
3	AC or DC return (Common to Housing)

\* The Alarm signal can be used with the ALM-1000 unit to provide an audible alarm and dry contacts for remote station monitoring. Be certain to check all connections, settings and voltages before applying power

## Indicator Lights

Indicator	Lights when
Pwr	Proper power is present.
Alrm	The loss of data alarm is activated there is no data present.
Sig	A data signal is being transmitted or received. At low data rates these indicators may blink with data.