

WARRANTY

All fiber optic transmission systems, products and accessories manufactured by Liteway, Inc. and its subsidiaries are fully tested prior to shipment and are warranted against defective materials and workmanship for a period of five full years from the date of the original shipment. Should a problem occur, a Return Material Authorization Number (RMA) must be obtained from Liteway Inc. at (516) 931-2800 and the item returned to Liteway, Inc. 166 Haverford Road, Hicksville, NY 11801, USA, prepaid. Liteway Inc. will then, at its option repair or replace the defective item.

Liteway, Inc. maximum liability under this warranty is limited to the cost of the defective item only. No contingent liabilities of any kind are either assumed or implied.

Any items returned to Liteway, Inc. that have been misused, abused, damaged, modified, connected or adjusted in any way contrary to the instructions furnished by Liteway, Inc. or repaired by unauthorized personnel will not be covered by this warranty. Any non-warranty repairs required will be quoted at the current rate for such services.



Important Notices



CAUTION !

AVOID DIRECT EXPOSURE TO BEAM.

All -7, -8, and -9 Models use laser diodes. These solid-state laser diodes are located in the optical ports of these units. Laser diodes produce invisible radiation that may be harmful to human eyes. Never look directly into the optical port of any fiber optic unit designed to operate with single-mode optical fiber.

NOT FOR LIFE SUPPORT SYSTEMS

Liteway, Inc. does not authorize or warrant any of its products or accessories for use in critical life support systems or applications of any kind.

OPERATING INSTRUCTIONS

LuxLink[®] Fiber Optic Modulated IRIG Transmission System

Models; IRGT-1501, IRGR-1501



The IRGT / IRGR-1501 system consists of the IRGT-1501 transmitter and IRGR-1501 receiver and will transmit modulated IRIG signals from one point to another.

Technical Specifications

Signal Bandwidth	100Hz - 500KHz (+0, -3dB)
In/Out Impedance	50 ohms
In/Out Signal Level	3 volt peak to peak (60 mA maximum)
Protocols	IRIG A,B,D,E,H; NASA36, IEEE-1344
Signal/Noise Ratio	60 dB/min
Linearity & THD	3% max
Operating Wavelength	850 (-1), 1310 (-3,-7), 1550 (-9)
Optical Loss Budget	0 - 12 dB
Fibers Accommodated	1 multimode (-1,-3), 1 single-mode (-7,-9)
Temperature Range	-35° to +75°C
Power Requirements	11-24 VAC/DC @150 mA
Physical Size (mm)	5.0"(127)L x 3.0"(76)D x 1.0" (25.4)W
System Delays	see table at end of manual

All specifications measured with 1Km of 62.5u multimode fiber.
All specifications are subject to change without prior notice.

Installation Instructions

The diagram below shows the typical installation of the IRGT-1501 and IRGR-1501 fiber optic IRIG transmission units. Both should be connected exactly as shown and an IRIG signal applied to the transmitter. To compensate for the unique fiber optic losses of your installation there is a level adjustment on the IRGR-1501. The receiver level adjustment should then be set for a 3 volt peak to peak IRIG output signal, or for proper operation of the IRIG terminal device. The range of the receiver level control is adequate to allow the full 0 - 13dB optical path loss range to be accommodated.

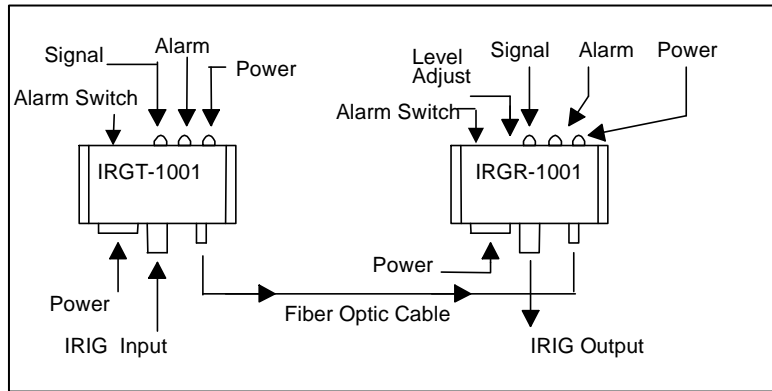

Power Terminal Block Connections

Pin	Function
1	Alarm output for use with optional Alarm Sensing Unit ALM-1000. No other connections should be made to this terminal
2	+11 to 24 DC or AC Volts input
3	AC or DC return (Common to Housing)

Be certain to check all connections, settings and voltages before applying power

The **Alarm** switch is used to turn the alarm function on and off.

Indicator Lights

Indicator	Lights when
Pwr	Proper power is present.
Alrm	The loss of signal alarm is activated and there is no video present
Sig	A IRIG signal is being transmitted or received.

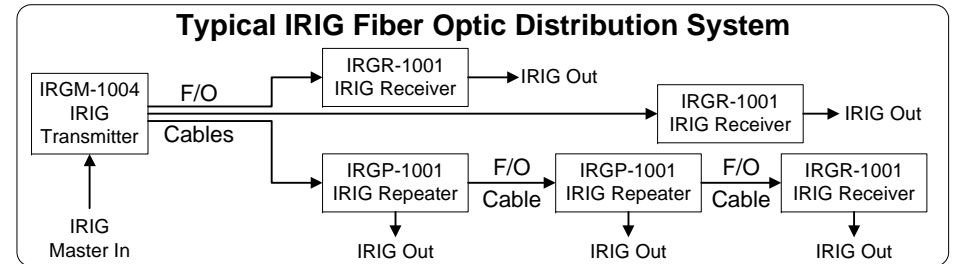
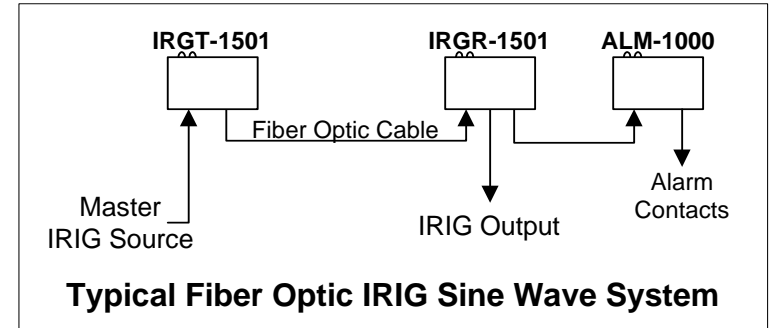

System Delays

	850 nm Multi mode	1310 nm Multi Mode	1310 nm Single mode
Transmitter	10 ns	3 ns	1 ns
Receiver	15 ns	15 ns	14 ns
System	25 ns	18 ns	15 ns

Note; Be sure to add 1ns per foot of fiber for total delay