

WARRANTY

All fiber optic transmission systems, products and accessories manufactured by Liteway, Inc. and its subsidiaries are fully tested prior to shipment and are warranted against defective materials and workmanship for a period of five full years from the date of the original shipment. Should a problem occur, a Return Material Authorization Number (RMA) must be obtained from Liteway Inc. at (516) 931-2800 and the item returned to Liteway, Inc. 166 Haverford Road, Hicksville, NY 11801, USA, prepaid. Liteway Inc. will then, at its option repair or replace the defective item.

Liteway, Inc. maximum liability under this warranty is limited to the cost of the defective item only. No contingent liabilities of any kind are either assumed or implied.

Any items returned to Liteway, Inc. that have been misused, abused, damaged, modified, connected or adjusted in any way contrary to the instructions furnished by Liteway, Inc. or repaired by unauthorized personnel will not be covered by this warranty. Any non-warranty repairs required will be quoted at the current rate for such services.



Important Notices



CAUTION! AVOID DIRECT EXPOSURE TO BEAM.

All -5, -7, -8, and -9 Models use laser diodes. These solid-state laser diodes are located in the optical ports of these units. Laser diodes produce invisible radiation that may be harmful to human eyes. Never look directly into the optical port of any fiber optic unit designed to operate with single-mode optical fiber.

NOT FOR LIFE SUPPORT SYSTEMS

Liteway, Inc. does not authorize or warrant any of its products or accessories for use in critical life support systems or applications of any kind.

OPERATING INSTRUCTIONS

LuxLink® Optical Bypass Switch

Single Channel Models OS-3122, OS-1202

Dual Channel Models OS-3222, OS-2202



The OS-3122 is a “fiber optic relay” that can be electrically controlled. The optical path through the units is purely mechanical. There is no optical to electrical to optical conversion. As a result, there is no data rate limitation or bandwidth limit on the fiber optic path. In addition, since the optical signal is not demodulated the optical data is totally secure. The optical path can be select via a front panel switch or via contact closure input. In event of loss of power, the unit has a fail safe mode that opens the switch. Common applications for this device are optical routing, system bypass, ring network restoration, and loop-back testing.

Technical Specifications

Switching Time	< 10 ms
Back Reflection	< -50dB
Insertion Loss	< 1.1 dB
Cross-talk	< -50dB
Mechanical Life	> 1 Million cycles
Electrical Connector	5 pin removable terminal block
Temperature Range	-35° to +70°C
Operating Power Requirements	11-24 VAC/DC @ 150 mA -48 VDC (+/-2) for OS-1202, OS-2202
Physical Size (mm) single	5.0”(127)L x 1.0” (25.4)W x 3.0”(7)D
Physical Size (mm) dual	5.0”(127)L x 2.2” (56.6)W x 3.0”(7)D

Models, wavelength, connector

-3 = 850/1310nm Multimode ST/PC	-4 = 850/1310nm Multimode- SC/PC
-5 = 850/1310nm Single-mode SC/PC	-7 = 1310/1550nm Single-mode FC/PC

Specifications are subject to change without prior notice.

Installation Instructions

Common applications for this device are optical routing, system bypass, ring network restoration, and loop-back testing.

The diagram below shows the typical application of the OS-3122.

The OS-3122 switch will go in a bypass state under any of the following conditions:

- 1) There is a loss of electrical power
- 2) The front panel mode switch is put into Bypass mode
- 3) The rear panel control signal is grounded

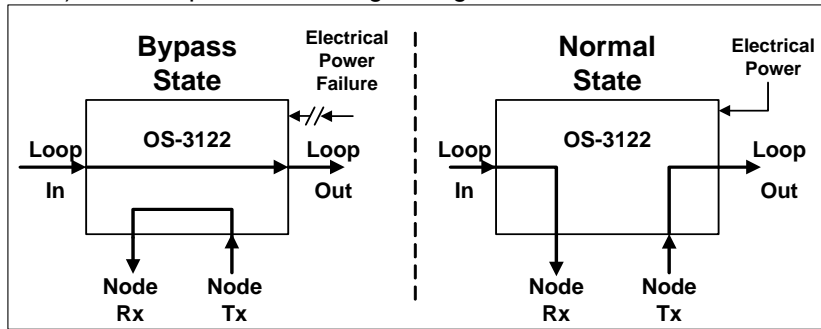

For applications where two independent optical channels need to be switched, the OS-3222 is two OS-3122 in a single enclosure.

For those that have telco applications, the OS-3122 and OS-3222 also are available as versions that operate from -48 VDC.

Power Signal Terminal Block Connections

Pin	Label	Function
1	Pwr+	Power + (see below for voltage)
2	Pwr-	Power - (see below for voltage)
3	Ctl	Control Signal (Connect to ground to place switch in bypass state)
4	Alm	Alarm* = gnd when optical switch is in a bypass state = Open when optical switch is in normal state
5	Gnd	Ground

* The Alarm signal can be used with the ALM-1000 unit to provide an audible alarm and dry contacts for remote station monitoring.

106129 Rev P

Power Pins Voltages

Pin	Models OS-3122 OS-3222	Models OS-1202 OS-2202
Pwr +	+11-24 Volts AC/DC	Ground
Pwr -	Ground	-48 Volts DC (+/- 2.0 Volts)

Indicator Lights

Indicator	Lights when
Power	Proper power is present
Normal	The switch is in normal state.
Bypass	The switch is in bypass state.

Front Panel Mode Selector

Position	Function
Bypass	Loop In optical port is routed to Loop Out optical port
Normal	Loop In optical port is routed to Node Rx optical port Loop Out optical port is routed to Node Tx optical port
Rmt	Loop In optical port is routed to Node Rx optical port Loop Out optical port is routed to Node Tx optical port except when rear control signal is activated or power is lost

OS-3122/3222-X-ISO

The ISO version of the OS-3122 and the OS-3222 is exactly the same as the non ISO version with the exception that there are no electrical connections to the housing. The metal housing is totally isolated from the circuitry of the unit.